



MECHANICAL-ASSIST MOBILE STORAGE SYSTEMS



EFFORTLESSLY MOVE ONE OR MORE CARRIAGES ALL AT ONCE

WITH ITS ENGINEERED GEAR RATIOS AND SUPERIOR QUALITY COMPONENTS, MONTEL CAN EASILY PROCLAIM TO HAVE THE BEST COMBINATION FOR THE SMOOTHEST RUNNING MOBILE STORAGE SYSTEMS.



THE BEST MECHANICAL-ASSIST MOBILE STORAGE SYSTEM



OPTIMIZE AND CUSTOMIZE YOUR STORAGE SPACE WITH MONTEL'S FLEXIBLE, HIGH-DENSITY MOBILE SHELVING SYSTEM

Easily recover floor space with the addition of new Montel shelving, existing shelving or racking securely mounted on Montel carriage and rail systems.



SAVE SPACE BY MOBILIZING YOUR STORAGE SYSTEM

Eliminate the need for multiple space-wasting static aisles and use the total potential of your vertical and horizontal space. Save 50% or more of your floor space or get 100% greater storage within the original floor space.

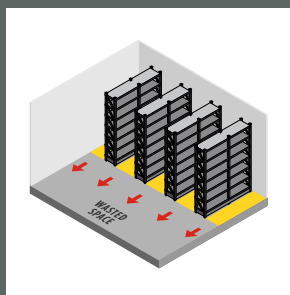

WASTED SPACE CONVENTIONAL FIXED SHELVING LAYOUT.

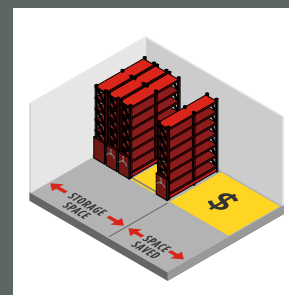

SPACE SAVED AND INCREASED PROFITABILITY MOBILE STORAGE SYSTEM LAYOUT. 50% OF FLOOR SPACE SAVED WITHIN SAME FOOTPRINT.

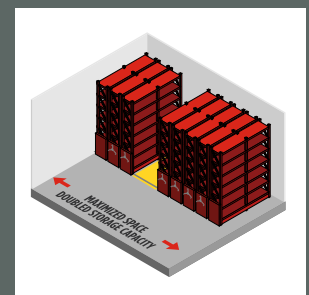

DOUBLED STORAGE CAPACITY AND INCREASED PROFITABILITY MOBILE STORAGE SYSTEM LAYOUT. 100% GREATER STORAGE WITHIN SAME FOOTPRINT.

MAXIMIZING VERSATILITY AND FUNCTIONALITY

Mobilex® is the ideal high-density mobile shelving system for any business or institutional setting. Montel's signature high-density movable storage system gives you the flexibility to customize your shelving while optimizing your capacity.

ENDLESS POSSIBILITIES. COST-EFFECTIVE SOLUTION.

The storage possibilities are endless: tires, plants, evidence, archives and office supplies, specimens and artifacts, sporting equipment, medical supplies, tools and parts and much, much more.

Whether mechanical or electrical, this cost-effective, high-density, movable storage solution is designed to accommodate various leading edge Montel shelving products. A wide range of accessories is also available: reference pull-out working shelves, hanging rods, bins, garment rods, drawers, hanging files and more. Further customize your mobile shelving system via our broad selection of optional safety, security, design and aesthetic features.

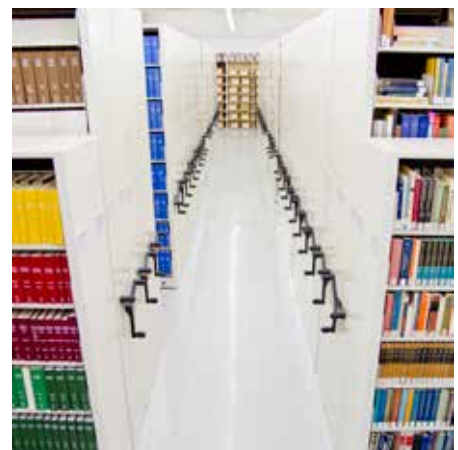

WHY MOBILEX®?

ONLY REQUIRES ABOUT 1 LB OF PRESSURE TO MOVE ONE OR MORE WHOLE UNITS AT ONCE. MOBILEX® IS ENGINEERED PRECISELY FOR HANDLING THE HEAVIEST WEIGHT WITH THE LIGHTEST EFFORT.

- DURABILITY & TROUBLE FREE MAINTENANCE
- BUILT FOR DECADES OF USE
- THE MOST USER-FRIENDLY HIGH-DENSITY MOBILE STORAGE SYSTEM
- A HIGHLY SECURE MOBILE STORAGE SYSTEM
- INCREASE PRODUCTIVITY BY SAVING TIME AND COSTS
- THE ONLY GOOD SOLUTION IS A CONFIGURABLE AND RECONFIGURABLE SOLUTION
- GROW FROM THE INSIDE

DID YOU KNOW?

MOBILEX® CARRIAGES HAVE A MAXIMUM LOAD CAPACITY OF 1,000 LB PER LINEAR FOOT (1,488 KG PER LINEAR METER)

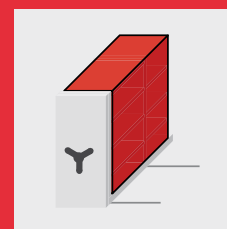

EX: 25 FT (7.62 M)
LONG CARRIAGES
HOLDS 25,000 LB
(11,340 KG)

MOBILEX®

MOBILEX® CARRIAGES CAN BE UP TO 45 FEET (13.7 M) LONG WITH A MAXIMUM LOAD CAPACITY OF 45,000 LB (20,412 KG). ELECTRICAL POWERED CARRIAGES CAN BE UP TO 100 FEET (30.5 M) LONG WITH A MAXIMUM LOAD CAPACITY OF 100,000 LB (45,359 KG).

THE CONCEPT

OPTIMIZE YOUR STORAGE SPACE

MONTEL HIGH-DENSITY STORAGE SYSTEMS MAXIMIZE THE USE OF AVAILABLE SPACE, WHETHER TO INCREASE STORAGE CAPACITY, FREE UP ROOM FOR PRODUCTION OR OTHER USES, OR GET RID OF SPACE YOU DO NOT NEED TO PAY FOR.

ELIMINATE THE NEED FOR MULTIPLE SPACE-WASTING STATIC AISLES.

1. Static units are mounted on mobile carriages.
2. Mobile carriages travel on tracks.
3. Open the desired aisle.
4. Press the aisle safety push-button located at the center of the handle.

SPACE WASTING STATIC AISLES



WASTED SPACE CONVENTIONAL FIXED RACKING LAYOUT.

Conventional storage systems require space-wasting fixed aisles.

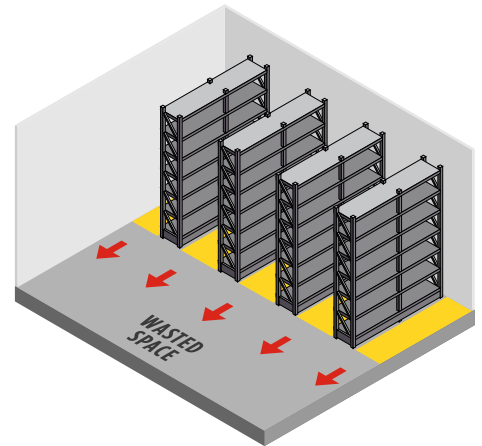

MODES OF OPERATION



Large SafeCrank Handle with aisle safety push-button.



Small SafeCrank Handle with aisle safety push-button. Ideal for narrow panels less than 20" wide (508 mm).

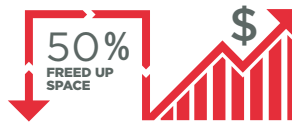

SPACE SAVED & INCREASED PROFITS MOBILE STORAGE LAYOUT.

50% of floor space saved within same footprint.

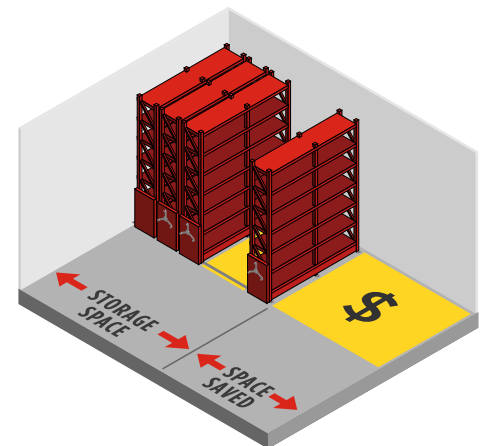

AVAILABLE WITH SAFEAISLE® MOBILE SYSTEMS* REFER TO SAFEAISLE® BROCHURE FOR MORE INFORMATION



Powered mobile storage systems 3-button control.



Powered mobile storage systems control with PIN for restricted access.



Powered mobile storage systems touchscreen tablet control with or without PIN code. Limitless customizable displays.



DOUBLED STORAGE CAPACITY. MAXIMIZED SPACE & INCREASED PROFITS MOBILE LAYOUT.

100% greater storage within same footprint.

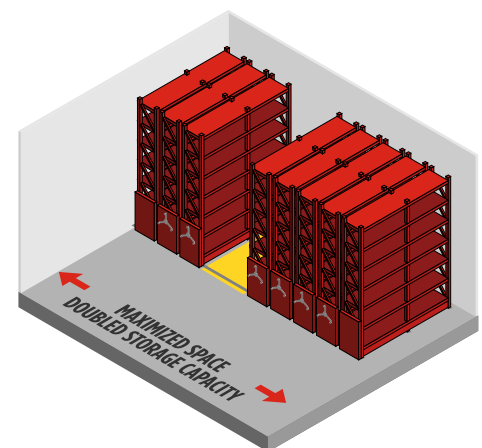

* The optional and patented Aisle LED Guard™ guarantees complete safety coverage throughout the aisle protecting users and objects.

BEST-IN-CLASS SAFETIES

EXPERIENCE THE INDUSTRY'S SAFEST MECHANICAL-ASSIST MOBILE STORAGE SYSTEM

SAFECRANK AISLE SAFETY PUSH-BUTTON

STANDARD SAFETY

To operate the system, rotate the SafeCrank handle clockwise or counterclockwise. To lock or unlock the SafeCrank handle, simply press the aisle safety push-button located at the center of the handle. A locked handle prevents the engaged mobile unit from moving. Mobile units on both sides of an aisle in use must be locked to ensure user safety.



UNLOCKED



PUSH TO LOCK OR UNLOCK



LOCKED

AISLE SAFETY PUSH-BUTTON LOCK

- Large round push-button lock easier to press and depress
- Visible red rim along the outer rim when locked
- Band acts as a color-coded visual indicator of its locked state

GRAVITY-FED MECHANICAL SAFETY BRAKE

OPTIONAL SAFETY

Montel's patented mechanical safety brake ensures complete protection for users and objects. The toe-level bar, when engaged, will automatically stop the carriage. Only light pressure is needed for the bar to activate the mechanism.

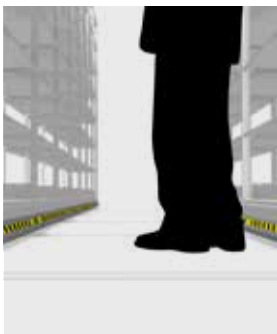

US PATENT # 7,645,000 / CANADA PATENT # 2,545,090



SHOCK ABSORBER COUPLING



GRAVITY-FED MECHANICAL SAFETY BRAKE

- Gravity-fed patented concept
- No brake adjustments needed after installation
- Shock absorber coupling
- Smooth braking

SAFECRANK ERGONOMIC 3-SPOKE HANDLE

EASY & SMOOTH ROTARY MOTION



AVAILABLE HANDLES

SafeCrank handles provide a convenient handgrip at a comfortable level of operation and an easy and smooth rotary motion from any starting position. SafeCrank handles are ADA Compliant. 

LARGE SAFECRANK HANDLES



- Integrated aisle safety push-button safety
- Large SafeCrank handles are offered in Black, Montel Red, and Polar White

SMALL SAFECRANK HANDLES



- Ideal for narrow panels less than 20" wide (508 mm)
- Integrated aisle safety push-button safety
- Available in Black only

FEATURES & BENEFITS

THREE-LOCK HUBS



- Three-lock hubs secure the handle in locked position when circular hub is pressed
- Three round detents keep carriage movement locked down

THREE SOFT-TOUCH ERGO GRIPS



- 1 3/4" (44.4 mm) Diameter x 2" long (50.8 mm)
- Ensures a comfortable and safe grip
- Made of comfort-grip fiberglass-filled polypropylene
- Ergonomic design to fit the hand
- Drive knob turns in your hand for easier carriage movement

DUAL ACCESS

OPTIONAL

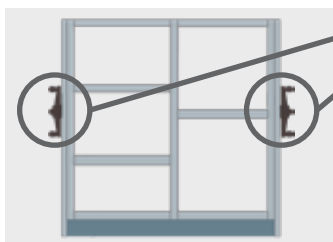

- Mobile system accessible at each end of mobile units
- Handles located at each extremity

MOBILEX[®]

VALUE YOU CAN COUNT ON



Of all the mobile storage system on the market, Mobilex[®] stands in a class of its own. This pioneering system with a proven design constantly evolving with changing needs. A wise investment anytime, it gives you incredible value for your storage dollar. Mobilex[®] adapts perfectly to your access, conservation, and safety priorities, regardless of the size, weight, dimensions, and value of your objects. Reliable, durable, and flexible, Mobilex[®] optimizes your storage space in complete safety.

TRACK & FLOOR SURFACE OPTIONS

SURFACE MOUNTED RAIL MOUNTED ON TOP OF A LEVELED CONCRETE FLOOR

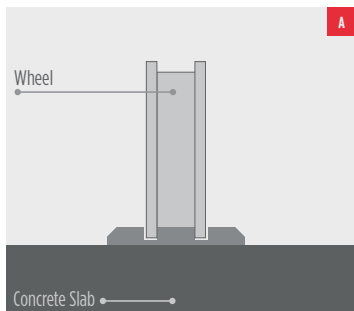

RECESSED TRACK EMBEDDED IN CONCRETE

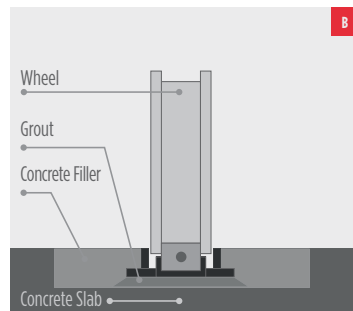

FLOOR MOUNTED TRACK CONCRETE PAD

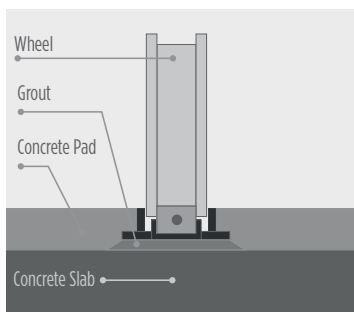

FLOOR MOUNTED TRACK PLYWOOD DECKING

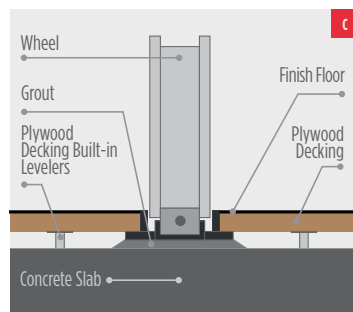

MONTEL PRODUCT SHOWN IS A HD 16MA WITH SURFACE MOUNTED STEEL RAIL ON CONCRETE FLOOR.



RECESSED TRACK EMBEDDED IN CONCRETE.

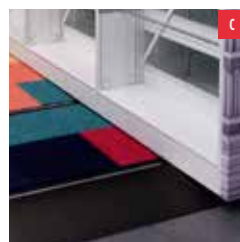

FLOOR COVERING MATERIALS SUCH AS CARPET, TILE, LAMINATE AND VINYL CAN BE APPLIED OVER PLYWOOD DECKING.

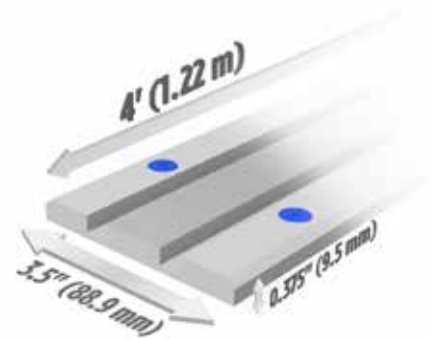

SURFACE MOUNTED RAIL

One-piece solid steel rail system for surface mount applications on a leveled slab. Anchored directly to the concrete slab with a chamfered edge flush fit design to reduce tripping hazards and allow carts to easily roll over. Steel rail treated against oxidation with a heavy-duty powder coated paint.

SURFACE MOUNTED RAILS ARE AVAILABLE IN 4-FOOT SECTIONS (122 CM)

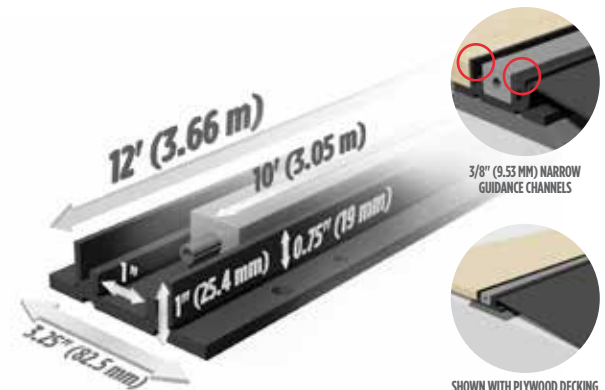

3/8" (9.53 MM) NARROW GUIDANCE CHANNELS



SHOWN WITH PLYWOOD DECKING & TEXTURED SLIP-RESISTANT RAMP

RECESSED OR FLOOR MOUNTED TRACK

Leveled track design with a solid steel rail embedded into grouted aluminum sub-rail for superior strength and load distribution to the concrete slab. Narrow guidance channels reduce tripping hazards and allow carts to easily roll over.

ALUMINUM SUB-RAILS ARE AVAILABLE IN 12-FOOT SECTIONS (3.66 M)
STEEL RAILS ARE AVAILABLE IN 10-FOOT SECTIONS (3.05 M)

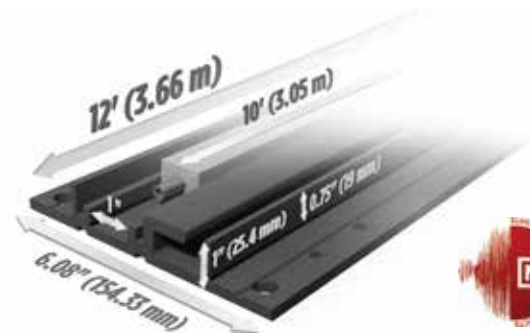

BUILT-IN ANTI-TIP RECESSED OR FLOOR MOUNTED TRACK

Built-in anti-tip leveled track design with a solid steel rail embedded into a grouted aluminum sub-rail with anti-tip channels for both seismic and high shelving applications which also provides for superior strength and load distribution to the concrete slab. Narrow guidance channels reduce tripping hazards and allow carts to easily roll over.

ALUMINUM SUB-RAILS ARE AVAILABLE IN 12-FOOT SECTIONS (3.66 M)
STEEL RAILS ARE AVAILABLE IN 10-FOOT SECTIONS (3.05 M)

MOBILE[®] FEATURES & BENEFITS & TRACK OPTIONS COMPARISON CHART

				SURFACE MOUNTED	RECESSED	FLOOR MOUNTED	
SURFACE MOUNTED		SURFACE MOUNTED RAIL <ul style="list-style-type: none"> • Unleveled surface mount rail for leveled floor • 3/8" (9.5 mm) high x 3 1/2" (88.9 mm) wide 	<ul style="list-style-type: none"> • Heavy-duty paint against oxidation caused by concrete • Easy installation 	<ul style="list-style-type: none"> • Beveled Edges design and narrow channels to reduce risk of tripping hazards • Wood floor, grout or shims are not required 	✓		
	OR						
RECESSED OR FLOOR MOUNTED TRACK OPTIONS		CORROSION-RESISTANT ALUMINUM SUB-RAIL <ul style="list-style-type: none"> • Acts as barrier between the concrete and the hardened steel rail 	<ul style="list-style-type: none"> • Prevents rust in a corrosive concrete environment 		✓	✓	
	OR						
RECESSED OR FLOOR MOUNTED TRACK		BUILT-IN ANTI-TIP ALUMINUM SUB-RAIL <ul style="list-style-type: none"> • Provides stability and safety • Meets the most severe seismic regulations 	<ul style="list-style-type: none"> • Provides safety for systems with a high height-to width ratio 	<ul style="list-style-type: none"> • Meets UBC requirements  	✓	✓	
	RECESSED OR FLOOR MOUNTED TRACK		TWO ANTI-SLIP GROOVES <ul style="list-style-type: none"> • Grout infiltrates under the sub-rail and inside the grooves thus preventing lateral movement if pouring concrete topping 			✓	✓
		INTERLOCK STEEL RAIL CONNECTOR <ul style="list-style-type: none"> • Eliminates rail separation 	<ul style="list-style-type: none"> • Ensures gradual transfer of the concentrated wheel point load to and from adjoining rail sections 	<ul style="list-style-type: none"> • Provides horizontal and vertical continuity between rail sections 	✓	✓	
		PIN ANCHORING AT EACH TRACK END <ul style="list-style-type: none"> • Ensures perfect position of rail 			✓	✓	
		TWO-PIECE SPLICELESS TRACK <ul style="list-style-type: none"> • Continuously supports the top hardened steel rail at the junction point • Eliminates track deflection • Provides a quiet operating system 	<ul style="list-style-type: none"> • Ensures smooth weight transfer from one track section to the other • Easy and instant removal and replacement of the top hardened steel rail compared to a one-piece rail 	<ul style="list-style-type: none"> • Ensures that all rail connection joints provide horizontal and vertical continuity between rail sections • Provides greater structural rigidity 	✓	✓	
		OFFSET SUB-RAIL AND RAIL SPLICE JOINTS FROM ONE ADJOINING <ul style="list-style-type: none"> • Prevents the adjoining rail splice to be at the same location 	<ul style="list-style-type: none"> • Prevents the wheels of a same carriage to cross a rail splice joint at the same time 	<ul style="list-style-type: none"> • Ensures a better weight load distribution • Eliminates any rail deflection 	✓	✓	
		FULLY-GROUTED ALUMINIUM SUB-RAIL <ul style="list-style-type: none"> • Fully supported to evenly distribute the weight on the existing slab 	<ul style="list-style-type: none"> • No shims needed 		✓	✓	
LEVELING & ANCHORING FLOOR MOUNTED TRACK			PRECISION LEVELING SCREWS <ul style="list-style-type: none"> • Provide more precision and adjustability versus shimming 	<ul style="list-style-type: none"> • Provide a quality rail installation which ensures long-term reliability 		✓	✓
		PLYWOOD DECKING BUILT-IN LEVELERS <ul style="list-style-type: none"> • Provide more precision and adjustability than shimming 	<ul style="list-style-type: none"> • Provide an accurate and continuous flush floor surface 	<ul style="list-style-type: none"> • Faster and more efficient to install 		✓	
TEXTURED SLIP-RESISTANT STEEL RAMPS FLOOR MOUNTED TRACK		STEEL RAMP WITH TEXTURED SLIP-RESISTANT PAINT <ul style="list-style-type: none"> • 8.8" (22.35 cm) wide steel ramp with textured anti-slip black paint • 10-degree slope • Made of 12 gauge cold rolled steel 	<ul style="list-style-type: none"> • Ramp makes a smooth transition from the floor to the mobile system's false floor to prevent tripping and allow carts to easily roll over 	<ul style="list-style-type: none"> • Ramp can be covered with carpet or vinyl flooring tiles • Optional 3M[™] Safety-Walk[™] slip-resistant tape 		✓	
	OR						
		ADA STEEL RAMP WITH TEXTURED SLIP-RESISTANT PAINT ♿ <ul style="list-style-type: none"> • 19" (48.26 cm) wide ADA steel ramp with textured anti-slip black paint • 5-degree slope to meet ADA regulations • Made of 12 gauge cold rolled steel 	<ul style="list-style-type: none"> • Ramp makes a smooth transition from the floor to the mobile system's false floor to facilitate wheelchair access, prevent tripping, and allow carts to easily roll over 	<ul style="list-style-type: none"> • Ramp can be covered with carpet or vinyl flooring tiles • Optional 3M[™] Safety-Walk[™] slip-resistant tape 		✓	

SUPERIOR DURABILITY & TROUBLE-FREE MAINTENANCE



CARRIAGES | WHEELS & GUIDANCE | SHELVING ANCHORING



ALL-RAIL DIRECT-DRIVE SYSTEM

- Direct drive mechanism
- Full length drive shaft wheel at every rail location. This creates uniformly distributed pulling forces
- Large diameter torque-resistant drive shaft provides power to **all wheels** connected to the line shaft
- No multiple internal chain mechanisms and drive shafts which would require more maintenance
- Prevents fishtail with unbalanced loads
- Reduces stress on the carriage structure
- Enhances stability and performance
- Provides positive tracking effect
- Extends life of the systems



TORQUE-RESISTANT TUBULAR DRIVE SHAFT

- Most durable shaft in the industry
- Lighter, stiffer and stronger structure
- Torsion resistance of 11,773 lb-in (1,330 N-m)
- Tubular drive shaft inside diameter: 1.045" (26.5 mm)
- Tubular drive shaft external diameter: 1.315" (33.4 mm)



STEEL C-SHAPED CROSS MEMBERS & CARRIAGE JOINTS

- Steel C-shaped members provide great structural strength
- Carriage joints allow smaller carriage sections, which provide easier shipping and facilitate the installation of long carriages despite physical limitations such as elevators
- Allows the extension of existing carriages by adding sections
- Bolted from the inside to provide a clean exterior finish without visible hardware



AERONAUTICAL RIVET BONDING CARRIAGE ASSEMBLY

- Prevents play and looseness thereby consistent and precise
- Expands when seated thus filling the space completely and providing maximum strength
- Eliminates distortion and reduces material stress caused by welding
- Facilitates system relocation
- Allows easy and economical carriage modifications

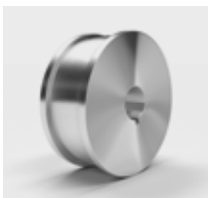

ALL 5" DIAMETER HARDENED STEEL WHEELS

- Provides larger turning diameter minimizing the number of wheel rotations and lowers the wear to the wheel
- Ensures a long-lasting system
- Provides greater strength
- Provides smooth and easy movement
- Prevents uneven wear since all wheels are the same diameter, as opposed to systems using a combination of 3-inch (76.2 mm) and 5-inch (127 mm) wheels



DOUBLE-FLANGED PRECISION-MACHINED 1045 HARDENED STEEL WHEELS

- Enables the system to move smoothly
- Minimizes vibration
- Minimizes wear and tear on the wheel thus reducing risk of maintenance problems
- Secure guidance even with an unbalanced system
- Rolling friction coefficient of less than 0.0117



LIFETIME LUBRICATED & SHIELDED BALL BEARINGS

- Minimum load rating of 3,540 lb (1,605 kg) per wheel
- Ensures a long system life and a smooth movement
- Bearings are maintenance free and provide smooth and easy movement



BEST-IN-CLASS SHELVING ATTACHMENT TO MOBILE CARRIAGE

- Full C Channel construction
- Design allows no visible hardware on front face of carriage
- Montel SmartShelf® rests on 5" (127 mm) high steel carriage
- Montel's bearing capacity is that of entire carriage
- SmartShelf® attached with two 4" (101.6 mm) bolts per frame versus only 3/4" (19 mm) tek screws as usually provided by other manufacturers

EXCEPTIONAL PERFORMANCE

DUE TO SUPERIOR QUALITY

A system's performance is proved over time, day after day, year after year. It's a matter of quality design, components, and installation. It's measured in superior durability and trouble-free maintenance. It's enhanced by the many special features that make our systems so pleasant to use. Simply put, we are performance professionals. Our systems are regularly tested by industrial research centers and independent laboratories. We continually invest in Research and Development to maintain and improve our reputation as a leader in quality. We capture the majority of bids where performance is the main selection criteria.

MOBILEX® OPTIONAL STAINLESS STEEL

Mobilex® Stainless Steel selective components can withstand rough corrosive conditions and is ideally suited for clean rooms found in hospitals, pharmaceutical manufacturing, and also corrosive environments such as cold storage applications, freezers, food manufacturing, kitchens, and even offshore platforms.

Mobilex® Stainless Steel components such as wheels and rails are made of stainless steel and drive shafts are treated with an anti-corrosion coating. Other components could be supplied in stainless steel on request upon factory's approval.



STAINLESS STEEL LOW PROFILE RAIL & WHEEL

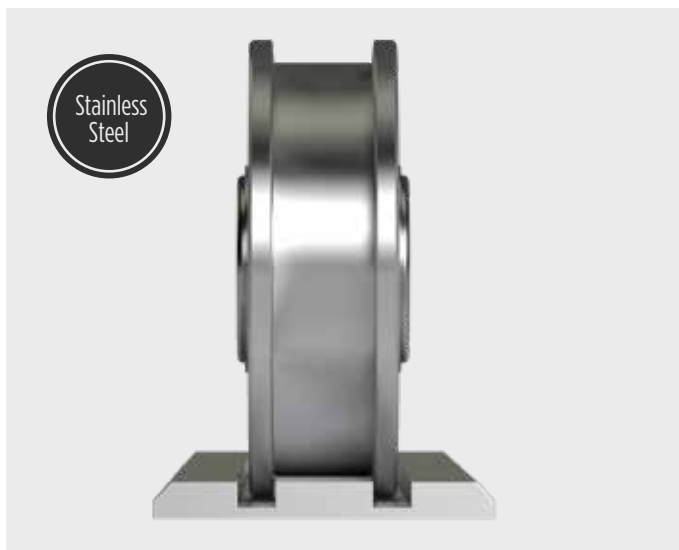

SURFACE MOUNTED

ALUMINUM SUB-RAIL & STAINLESS STEEL RAIL



RECESSED OR FLOOR MOUNTED TRACK

WHEN FLEXIBILITY MEETS SPACE EFFICIENCY

PATENT # 6,814,245

SMART SHELF®

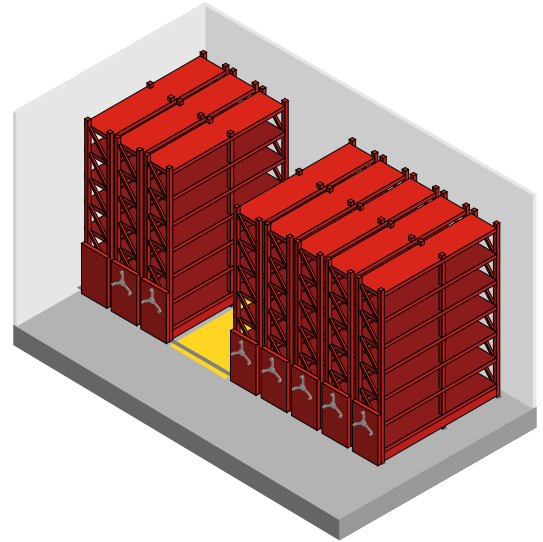

MOUNT SMARTSHELF® SHELVING SYSTEM ON MOBILEX® MECHANICAL-ASSIST MOBILE SYSTEM AND INSTANTLY REALIZE POSITIVE GAINS WITHIN YOUR AVAILABLE SQUARE FOOTAGE.

SmartShelf® 4-Post hybrid shelving system mounted on mechanical-assist mobile storage system

You can store anything with SmartShelf®. This new revolutionary shelving system was designed to be configured and reconfigured easily and efficiently. In fact, we offer the widest range of products in the market. We will go to any length, width or depth to optimize your space. The only good solution is a flexible solution.



YOU CAN ALSO MOUNT OTHER MONTEL SHELVING SYSTEMS ONTO MOBILEX® MOBILE CARRIAGES



4D-500, 4D-1000, 4D-1500 WIDE SPAN RACKING
IDEAL FOR BULK STORAGE. MAXIMUM LOAD CAPACITY PER TIER IS EITHER 500 LB (227 KG), 1,000 LB (454 KG) OR 1,500 LB (650 KG).



AETNASTAK
CANTILEVER SHELVING
IDEAL FOR LIBRARY SHELVING.



CABINET-STYLE
CASE-TYPE SHELVING
IDEAL FOR OFFICE & CORPORATE STORAGE.

GET MORE VERTICAL & HORIZONTAL SPACE

WITH SMARTSHELF® & MOBILEX®

PATENT # 6,814,245



TAKE SPACE EFFICIENCY TO A NEW LEVEL | MAXIMIZE YOUR STORAGE | OPTIMIZE YOUR SPACE

Our continuous quest for space optimization has led us to develop SmartShelf®, a shelving system that exceeds industry standards.

MORE STORAGE VERTICALLY ADJUSTABLE SHELVES IN 1" (25.4 MM) INCREMENTS

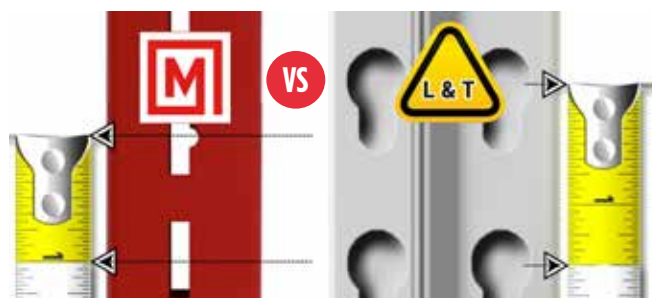

1" (25.4 MM)
SMARTSHELF® HYBRID SHELVING
SYSTEM WITH HOOKS

1 1/2" (38.1 MM)
L&T COMMODITY SHELVING

MORE STORAGE HORIZONTALLY 3/4" (19 MM) MORE USABLE STORAGE PER SHELF

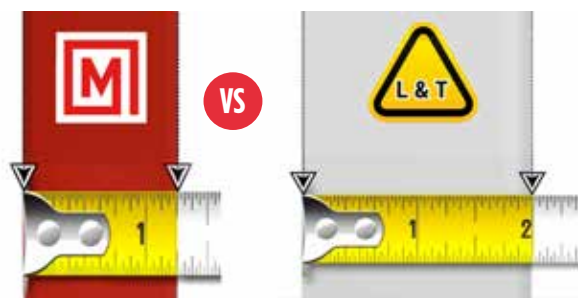

1 1/4" (31.75 MM)
SMARTSHELF® HYBRID SHELVING

2" (50.8 MM)
L&T COMMODITY SHELVING

DO THE SMARTSHELF® MATH

100 SECTIONS OF 97" (246.38 CM) HIGH
WITH 8 TIERS OF BACK-TO-BACK SHELVING
UNITS WOULD REPRESENT:

NOTE: WHAT ABOUT THE ADDITIONAL STORAGE VERTICALLY
DUE TO THE 1" INCREMENTS VS. L&T AT 1 1/2" INCREMENTS.
ADD THESE EXTRA LINEAR INCHES TO YOUR TOTAL.

8 TIERS
X 2 BACK-TO-BACK SHELVING UNITS
X 3/4" (19 MM) MORE STORAGE PER SHELF
= 12" (30.48 CM) MORE USABLE STORAGE PER SHELVING UNIT
X 100 SECTIONS

**= 1,200" (30.48 M) ADDITIONAL LINEAR INCHES
OF STORAGE WITH SMARTSHELF® VS. L&T**

COMBINED FLEXIBILITY TO STORE VIRTUALLY ANYTHING

EVERYTHING IS NOW POSSIBLE WITH SMARTSHELF® TAKE SPACE EFFICIENCY TO A NEW LEVEL

SmartShelf® is designed to be configured and reconfigured easily and efficiently. Shelves and accessories are interchangeable. That way, they can grow and evolve according to your future storage needs.

SMART SHELF®

PATENT # 6,814,245

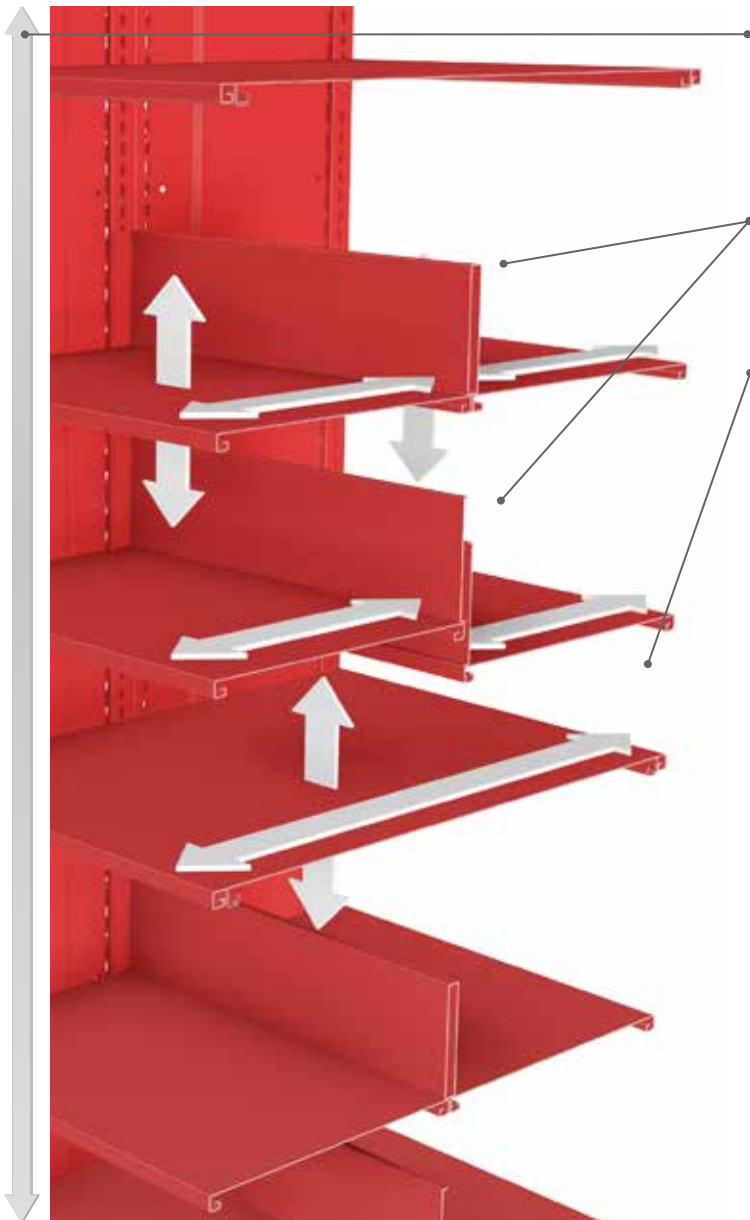

FROM ONE TIER TO THE NEXT

SmartShelf® is the only storage system that can be configured with back-to-back or double face full depth shelves, or any combination of both.

BACK-TO-BACK SHELVES

The shelf system is independently adjustable on both sides for many storage possibilities. Easy to assemble and reconfigure.

DOUBLE FACE FULL DEPTH SHELVES

For storing large objects of various lengths, shapes and sizes.

SHELVING SYSTEM WITH HOOKS: EASY TO RECONFIGURE & NO TOOLS REQUIRED



DID YOU KNOW?

Montel SmartShelf® shelving with hooks can hold up to 250 lb (113.4 kg) although can potentially withstand up to 500 lb (226.8 kg) depending on shelf dimensions.

SHELVING SYSTEM WITH SHELF SUPPORTS & REINFORCEMENTS | OPTIONAL

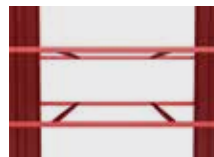

DID YOU KNOW?

Montel SmartShelf® shelving with supports and reinforcements can hold heavier objects than SmartShelf® shelving with hooks and can withstand up to 500 lb (226.8 kg).

ACCESSORIES

UNLIMITED POSSIBILITIES



DRAWER CABINET WORKBENCH



SMARTSHELF® SHELVING RUN ON CASTERS WITH ROLLING SHUTTERS



BIN DIVIDERS



SLAT STEEL PANEL WITH UPFRONT DISPLAY SHELF & WORKING COMPUTER SHELF



FORKLIFT BASE



MOBILEX® WITH PATENTED AISLE SAFETY BRAKE (1) | PULL-OUT DRAWERS (2)



ADA COMPLIANT RAMP



LED AISLE LIGHTING



STURDY PULL-OUT REFERENCE SHELF



WHITEBOARD END PANELS



UNIVERSAL CROSSBARS WITH BIKE SUPPORT*



GARMENT RODS | BIN DIVIDERS | FRONT STOPS



WIRE SPOOL RODS



VERTICAL COMPARTMENTS | ARTWORK BINS



FRONT STOPS



UNIVERSAL CROSSBARS WITH HANGING RODS*



LARGE FRONT STOPS | GARMENT ROD



PULL-OUT DRAWERS



ROLLING SHUTTERS DOORS



SLIDING TRAY



COMPARTMENTS WITH HINGED DOORS | PERFORATED BACK PANELS



LOUVERED PANELS FOR PLASTIC BINS



ADJUSTABLE BINS ON EITHER SIDE



PERFORATED TRAY



MOBILE SYSTEM WITH UPFRONT STORAGE



COMPARTMENTS WITH HINGED DOORS | PERFORATED BACK PANELS



SLAT WALLS FACE PANELS (1), SLAT WALLS BACK PANELS (2), ADJUSTABLE HANGING BINS UPFRONT (3)



PERFORATED SHELVES



ADJUSTABLE HANGING BINS UPFRONT



SMARTSHELF® MOBILE CABINET ON CASTERS

* PROVIDED WITH AETNASTAK CANTILEVER SHELVING

CASE STUDY

HYATT REGENCY

HYATT REGENCY INDULGES ITS GUESTS WITH A NEW LUGGAGE ROOM
FURNISHED WITH MOBILE SHELVING

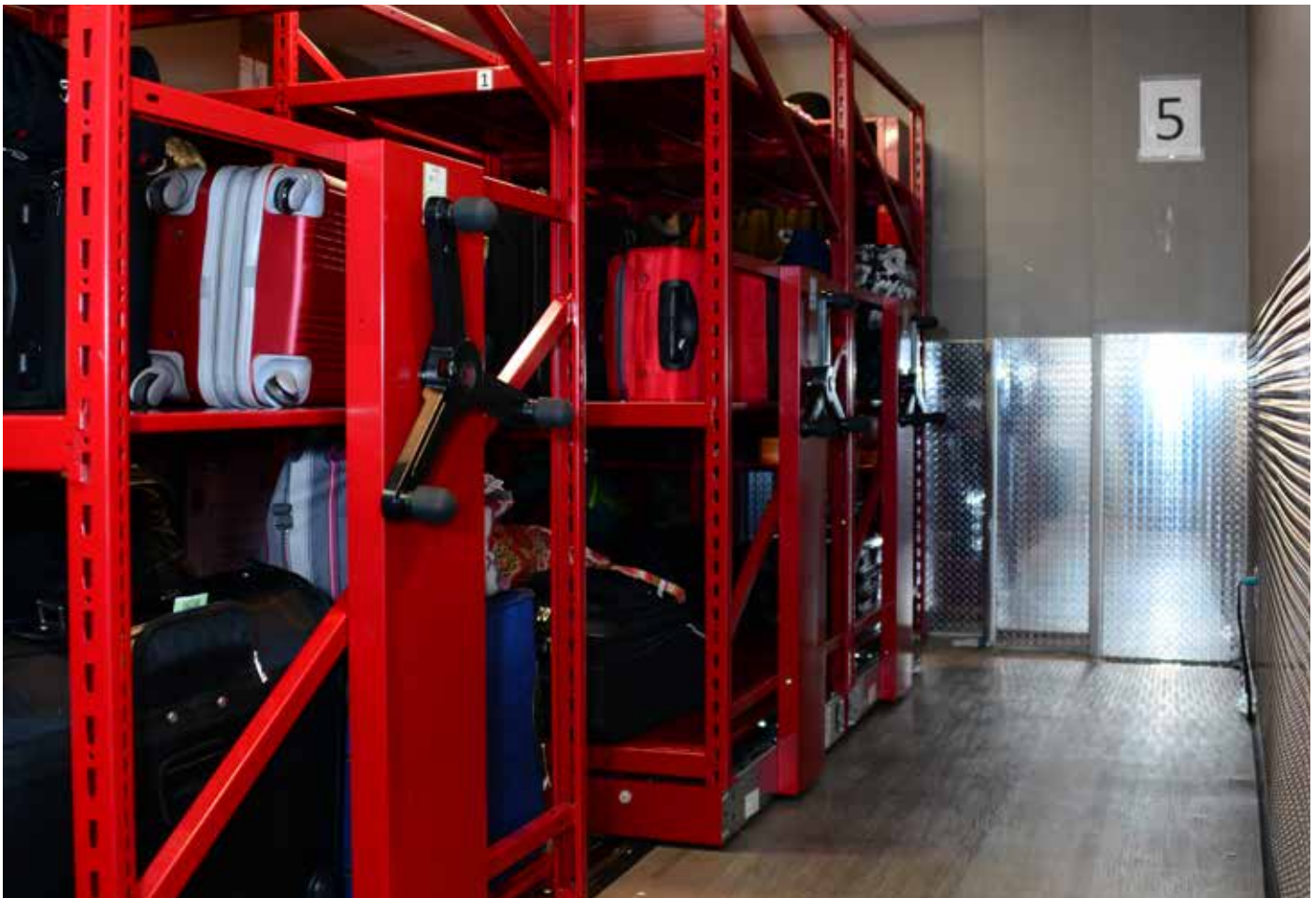



MOBILEX® WITH SMARTSHELF® 4-POST SHELVING

 HEALDSBURG, CALIFORNIA, USA

“ We can now double luggage storage capacity.
We are able to retrieve luggage 75% faster. ”

CHALLENGES

Hyatt Regency partnered with Montel to redesign its luggage storage room so its team of bellhops could more adequately provide for Hyatt guests.

SOLUTIONS

Even the fanciest establishments know a thing or two about the value of spatial economy. That’s why outfitting the luggage room with a 4D wide span Mobilex® mobile shelving installation makes the most sense. Thanks to its collapsible design, mobile shelving helps the Hyatt store more bags and other materials with half the storage footprint.

For Hyatt regency bellhops, the difference was night and day. The mobile shelving installation expanded the Hyatt’s luggage storage capacity by 250 percent, up to as many as 500 bags and suitcases. Hyatt Regency Bell Captains also told Montel their bellhops are now able to retrieve luggage 75 percent faster thanks to the organization achieved by their new mechanical-assist mobile shelving modules.

PRODUCT FEATURES

Mobilex® mobile shelving systems offer hotels the flexibility to reshape their luggage storage themselves without the need for tools or maintenance professionals. Heavy-duty wide span shelving can be adjusted in 1-inch increments to accommodate large suitcases or any unusually shaped objects visitors might have in tow.

Better still, Mobilex® shelving can include other kinds of storage features to create multipurpose spaces. A luggage room could also be a coat check if, like the Hyatt Regency, hotels added clothing racks with garment rods to their luggage storage installations. Furthermore, hotels could also tack on a few extra mobile shelving modules and use the additional space for general storage.

Even shelving has the power to knock guests off their feet if it makes a statement or blends well with the decor. The Hyatt chose a breathtaking shade of deep red for its luggage room storage, but other hotels can choose from an array of color options that suit their tastes.



CASE STUDY

WILLIAMS SELYEM WINERY

WILLIAMS SELYEM WINERY LEARNED WORLD-CLASS WINES
PAIR WELL WITH SMARTER SHELVING





MOBILEX® MOBILE SHELVING

 HEALDSBURG, CALIFORNIA, USA

“ We’d like to personally thank Montel for a job well done. ”

CHALLENGES

Wine libraries must be kept at an even temperature using heating, ventilation and air conditioning systems specifically designed to create an ideal environment. While these HVAC systems preserve the wine well, they do increase energy costs for the user as they must run constantly. Expanding the square footage of the library to make room for more storage would have not only cost a bundle in construction, but also raised the recurring energy costs for the winery.

SOLUTIONS

After partnering with Montel and installing six 16-foot Mobilex® mobile shelving modules across the wine library’s two rooms – along with freestanding racks along that back walls – Williams Selyem effectively quadrupled its storage potential to 2,000 cases, give or take a few dozen boxes of Magnum bottles. Instead, Williams Selyem trusted mobile shelving to grow its storage capabilities without increasing its energy consumption.

BENEFITS

Like traditional libraries, Williams Selyem Winery wine library serves a purpose beyond simple storage. Batches stored therein require frequent testing to determine whether they are mature enough for sale. Williams Selyem wine specialists need room to pull designated batches from the shelves and taste them. With that in mind, the space cannot be cramped or completely devoted to storage. Luckily, because of the collapsible Mobilex® mobile shelving units, Williams Selyem staff can open and close aisles to give themselves enough space to freely move about the wine library at their leisure.



MOBILEX® ROI RETURN ON INVESTMENT REPORT

COST OF MONTEL MOBILE STORAGE SYSTEM VS. ANNUAL COST OF STOCKROOM RENT

ESTIMATED COMMERCIAL LEASE – TOMBALL, TX
 PRODUCT: MOBILEX® WITH 4D WIDE SPAN



MONTEL MOBILEX®
 WITH 4D WIDE SPAN RACKING

ANNUAL STOCKROOM RENT	
Lease per sq. ft.	\$17.00
HVAC Cost per sq. ft.	\$1.50
Stockroom Taxes & Maintenance	\$0.50
Total Annual Lease Per sq. ft.	\$19.00/sq. ft.

Source: LoopNet - <http://www.loopnet.com/Listing/19079406/27400-State-Highway-249-Tomball-TX/>

	ROI IN 28 MONTHS
Montel Mobile Storage System Investment*	\$16,800
Recovered Warehouse Space	382 sq. ft.
Yearly Rent on Freed Up Space (382 sq. ft.. x \$17 annual rent per sq. ft.)	\$6,494
HVAC & Utilities (382 x \$1.50 annual cost per sq. ft.)	\$573
Insurance, Maintenance, Taxes (382 sq. ft. x \$0.50 annual cost per sq. ft.)	\$191
Total Savings in Leasing per Year	\$7,258
ROI	28 Months
ROI AFTER 10 YEARS = (\$7,258 x 10 Years) - \$16,800	\$55,780

Warehouse costs were too expensive compared to a Montel mobilized racking solution.

* Pricing includes mobile system and installation cost.

MOBILEX® LEED RATINGS

LEADERSHIP IN ENERGY AND ENVIRONMENTAL DESIGN (LEED®) GREEN BUILDING RATING SYSTEMS IN NORTH AMERICA.

This document explores the potential contribution for the use of MONTEL HIGH-DENSITY STORAGE SYSTEMS for a LEED® (New Construction and Major Renovations) project. The LEED® Rating System has 110 points divided in seventeen topics for certifying the design and construction of commercial or institutional buildings and high-rise residential buildings of all sizes, both public and private. Montel's storage products can assist in earning points towards the various LEED rating system certification levels. In some cases, Montel's high-density mobile storage systems contribute directly to individual LEED points, but in other cases can only help meet the overall intent.

LEED® SUMMARY TABLE					MONTEL PRODUCT POTENTIAL CONTRIBUTION
CATEGORY		PREREQUISITES	CREDITS	POINTS	LEED®
SS	Sustainable Sites	1	8	26	0 points
WE	Water Efficiency	1	3	10	0 points
EA	Energy and Atmosphere	3	6	35	0 points
MR	Materials and Resources	1	8	14	6 points
IEQ	Indoor Environmental Quality	2	8	15	3 points
ID	Innovation in Design	0	2	6	3 points
RP	Regional Priority	0	1	4	4 points
TOTAL		8	36	110	Up to 16 possible points

WE BUILD SATISFACTION

Established in 1924, Montel pioneered high density mobile storage systems providing cost-efficient storage solutions using less space.

CUSTOM-BUILT FOR YOUR INDUSTRY
WE'VE MANUFACTURED AND INSTALLED THOUSANDS OF PROJECTS AROUND THE WORLD.



MOBILEX® MECHANICAL-ASSIST MOBILE SYSTEM WITH 4D WIDE SPAN RACKING



SMARTSHELF® 4-POST HYBRID SHELVING SYSTEM



SAFEAISLE® POWERED MOBILE SHELVING SYSTEM



SAFEAISLE® POWERED MOBILE SHELVING SYSTEM



MOBILEX® MECHANICAL-ASSIST MOBILE SHELVING SYSTEM



SAFERAK® 32P POWERED MOBILE RACKING SYSTEM FOR COLD STORAGE

WHAT ELSE DO WE DO?
STORAGE SOLUTIONS THAT HELP YOU TO GROW FROM THE INSIDE, OPTIMIZE AND GET RESULTS.



HEAVY-DUTY MOBILE STORAGE SYSTEMS



SHELVING SYSTEMS



INDUSTRIAL MODULAR DRAWERS



CABINETS



WORKBENCHES



HANGING STORAGE SCREENS & PANELS

WHY CHOOSE MONTEL STORAGE SOLUTIONS?

SAVE SPACE | SAVE TIME | SAVE MONEY



GET RESULTS FROM YOUR SQUARE FOOTAGE: FAST ROI

Save up to 50 % of your value generating space.



WORK WITH STORAGE-SAVVY EXPERTS

We manufacture the one and only solution. The best one.



TOTAL OFFER CUSTOMIZED TO YOUR NEEDS

We will go to any length, depth, width, height, and weight.



BETTER ORGANIZE YOUR SKUs

Gain productivity while inventory management & security are improved.



MEET YOUR ENVIRONMENTAL OBJECTIVES

Minimize your environmental impact by reducing your footprint.

OUR MISSION

THE EMPLOYEES OF MONTEL SET OUT A VERY PERSONAL OBJECTIVE: BUILD THE BEST STORAGE SYSTEMS IN THE WORLD.

Their talent, commitment and dedication have been put to the test numerous times.

At Montel, client satisfaction is an ongoing priority. Our highly competent Authorized Montel Distributors are specialists in providing turnkey project solutions including space planning, design and floor loading consulting services, and factory certified system installations. They are also committed to providing a high level of professionalism and an outstanding customer service before and after the sale.

MONTEL INTERNATIONAL PRESENCE



68
COUNTRIES

MONTEL ACHIEVED PRESTIGIOUS REALIZATIONS IN MORE THAN 68 COUNTRIES

65
DISTRIBUTORS

65 AUTHORIZED MONTEL DISTRIBUTORS AROUND THE WORLD

SINCE
1924

MORE THAN 9 DECADES OF INNOVATIVE STORAGE SOLUTIONS

ALSO AVAILABLE

INQUIRE ABOUT OTHER MONTEL HIGH-DENSITY MOBILE STORAGE SYSTEMS DESIGNED TO HOLD VARIOUS LOAD CAPACITIES. MOBILE SYSTEMS ARE EITHER POWERED ELECTRICALLY, OPERATED MECHANICALLY OR MANUALLY.



SAFEAISLE®



RACK&ROLL 16MA



QUADRAL



SMARTSPACE 2M

CERTIFICATIONS & STANDARDS



For the most recent version of this document, please go to the Montel website at www.montel.com/en/design-center. In case of discrepancy, the web version takes precedence over any printed literature.



877-935-0236
info@montel.com
www.montel.com